



**EAST AFRICAN SCHOOL OF AVIATION
EXAMINATION**

END TERM I EXAMS

DIPLOMA IN AERONAUTICAL ENGINEERING AVIONICS

Aircraft Electrical Technology

STREAM: Module I (Avionics + Airframes & Engines)

Duration:

DAY/DATE:

TIME:

INSTRUCTION TO CANDIDATES

You should have the following for this examination:

Answer booklet;

Mathematical tables/ Electronic calculator.

Answer ANY THREE QUESTIONS IN SECTION A and ANY TWO IN SECTION B in this paper

All questions carry equal marks.

Maximum marks for each part of a question are as shown

This paper consists of Six (6) printed pages.

Candidates should check the question paper to ascertain that all the pages are printed as indicated and that no questions are missing.

SECTION A (Electrical Principles)

1. (a) Define the following terms.
- (i) Static electricity
 - (ii) Electric intensity
 - (iii) Electric displacement
 - (iv) Potential difference **(4 marks)**
- (b) State the three laws of electrostatics **(3 marks)**
- (c) Three point charges of $+16 \times 10^{-9}\text{C}$, $+64 \times 10^{-9}\text{C}$ and $-48 \times 10^{-9}\text{C}$, are placed at the corners of a square of 4 cm sides. Calculate the electric field at the fourth corner. **(7 marks)**
- (d) Three concentric spheres of radii 4, 6 and 8 cm have charges of +8, -6 and $+4\mu\text{C}$ respectively. What are the potentials and field strengths at points 2, 5, 7 and 10 cm from the center? **(6 marks)**
2. (a) the total capacitance of two capacitors is $0.3\mu\text{F}$ when joint in series and $0.16\mu\text{F}$ when connected in parallel. Find the capacitance of each capacitor. **(6 marks)**
- (b) Find the charges on capacitors in the figure below and the potential difference across them. **(4 marks)**

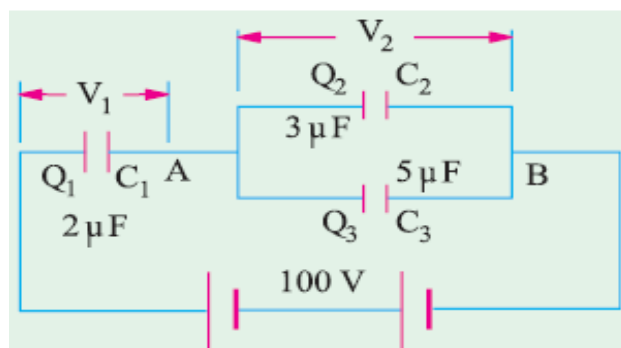

- (c) A parallel plate capacitor has plates of area 2 m^2 spaced by three slabs of different dielectric materials. The relative permittivities 2, 3, 6 and the thicknesses are 0.4, 0.6 and 1.2 mm respectively. Calculate the combined capacitance and the electric stress in each material when the applied voltage is 100V. **(6 marks)**
- (d) The radii of two spheres differ by 4 cm and the capacitance of this spherical capacitor is 53.33pF. If outer sphere is earthed, calculate the radii assuming air as dielectric. **(4 marks)**
3. (a) Briefly explain the following terms as used in magnetism and electromagnetism:-
- i. Magnetic field strength;
 - ii. Magnetic potential
 - iii. Flux density
 - iv. Absolute permeability
 - v. Intensity of magnetization **(5 marks)**
- (b) Two infinite parallel conductors carry parallel currents of 10 amperes each. Find the magnitude and direction of the force between the two conductors per meter length if the distance between them is 20 cm. **(5 marks)**
- (c) State the following:-
- i. Lenz law;
 - ii. Fleming's Right Hand Rule;
 - iii. Ohm's law;

iv. Faraday's 1st and 2nd law. **(5 marks)**

(d) Calculate the magnetizing force and flux density at the distance of 5 cm from a long straight circular conductor carrying a current of 250A and placed in air.

Draw a curve showing a variation of B from the conductor surface outward if its diameter is 2 mm. **(5 marks)**

4. (a) The inductance of a certain moving-iron ammeter is $(8 + 4\theta - 0.5\theta^2)$ where θ is the deflection in radians from the zero position. The control spring torque is 12×10^{-6} N-m/rad. Calculate the scale position in radians for a current of 2A.

(6 marks)

(b) With the aid of diagrams, explain how a galvanometer can be used as:-

(i) An ammeter **(3 marks)**

(ii) A voltmeter **(3 marks)**

(c) A moving coil voltmeter with a resistance of 10 Ohms gives reading of 25 mA when the p.d. across its terminals is 75 mV. Calculate:-

(i) The shunt resistance for a full scale deflection corresponding to 150A

(ii) The series resistance for full scale reading with 500V **(8 marks)**

SECTION B: AIRCRAFT INSTALLATIONS

5. (a) List FIVE classifications of d.c generators. **(5 marks)**
- (b) With the aid of circuit diagrams briefly explain the methods used in connecting the outputs of a three phase generator. **(6 marks)**
- (c) State the mathematical expressions for calculating the line voltage and current in each of the methods in question 1(b). **(4 marks)**
- (d) (i) Explain the terms “Frequency wild Generator“ as applied to aircraft electrical power. **(2 marks)**
- (ii) Name THREE types of loads that can be operated by a frequency wild generator. **(3 marks)**
6. (a) Describe the following sources of electrical power in an aircraft
- (i) Auxiliary power unit
- (ii) Ram Air Turbine **(8 marks)**
- (b) Explain the principle of operation of the following types of electrical power generating technologies used on an aircraft.
- (i) Constant Frequency Integrated Drive Generator (IDG).
- (ii) Variable Speed Constant Frequency Generators (VSCF).
- (iii) Constant Speed Drive Unit (CSDU). **(12 marks)**

7. (a) What is the function of busbars and how are they constructed. **(4 marks)**
- (b) Explain the operation of a typical Split busbar system. **(6 marks)**
- (c) Define THREE groups of busbars which categorize the importance of aircraft loads. **(6 marks)**
- (d) List the advantages of a Split Busbar System. **(4 marks)**
8. (a) With the aid of a diagram describe the principle of operation of an A.C generator. **(8 marks)**
- (b) State the functions of the following:-
- (i) Commutator
 - (ii) Slip rings
 - (iii) Bushes **(6 marks)**
- (c) (i) Name TWO types of batteries used on an aircraft **(2 marks)**
- (ii) State one precaution taken when using each of the batteries in c (i) **(2 marks)**

******End******