

2601/102

2602/102

2603/102

PHYSICAL SCIENCE, MECHANICAL  
SCIENCE AND ELECTRICAL  
ENGINEERING PRINCIPLES

June/July 2023

Time: 3 Hours



THE KENYA NATIONAL EXAMINATIONS COUNCIL

**DIPLOMA IN ELECTRICAL AND ELECTRONICS ENGINEERING  
(POWER OPTION)  
(TELECOMMUNICATION OPTION)  
(INSTRUMENTATION OPTION)**

**MODULE I**

PHYSICAL SCIENCE, MECHANICAL SCIENCE AND  
ELECTRICAL ENGINEERING PRINCIPLES

**3 hours**

**INSTRUCTIONS TO CANDIDATES**

*You should have the following for this examination:*

*answer booklet;*

*drawing instruments;*

*non-programmable scientific calculator*

*This paper consists of EIGHT questions in THREE sections; A, B and C.*

*Answer ONE question from section A, ONE question from section B and THREE questions from section C in the answer booklet provided.*

*All questions carry equal marks.*

*Maximum marks for each part of a question are as indicated.*

*Candidates should answer the questions in English.*

*Take,*

$$\mu_0 = 4\pi \times 10^{-7} \text{ H/M};$$

$$\epsilon_0 = 8.85 \times 10^{-12} \text{ F/M}$$

$$\text{Speed of light, } = 3.0 \times 10^8 \text{ m/s}$$

$$\text{Planks constant, } = 6.63 \times 10^{-34} \text{ J}$$

**This paper consists of 6 printed pages.**

**Candidates should check the question paper to ascertain that all the pages are printed as indicated and that no questions are missing.**



## SECTION A: PHYSICAL SCIENCE

Answer *ONE* question from this section.

1. (a) (i) Define the following terms as applied to radioactive decay:
- (I) half life;
  - (II) background radiation.
- (ii) Describe two sources of background radiation. (6 marks)
- (b) With the aid of a labelled diagram, explain the production of X-rays in an X-ray tube. (6 marks)
- (c) (i) State two properties of acids.
- (ii) An atom has a mass number of 35 and a charge number of 24:
- (I) determine the numbers of protons and neutrons in the atom;
  - (II) draw the electronic structure of the atom. (6 marks)
- (d) A light ray travelling through air strikes a glass interface at an incidence angle of  $30^\circ$ . If the refractive index of the glass is 1.55, determine the angle of refraction. (2 marks)
2. (a) Distinguish between the following types of waves, giving one example for each:
- (i) mechanical and electromagnetic waves;
  - (ii) transverse and longitudinal waves. (6 marks)
- (b) (i) Explain the term damping as applied to vibrations.
- (ii) With the aid of sketches, distinguish between under damped and over damped vibrations. (5 marks)
- (c) Two military boats are 240 m apart in a sea. A water wave traverses the sea such that when one boat is on a crest, the other is on a trough, with two other crests between the boats. The boats move up and down 30 times per minute. Determine the:
- (i) wavelength of the water wave;
  - (ii) speed of the wave in m/s. (5 marks)
- (d) (i) Define the term homologous series as applied to organic compounds.
- (ii) State four homologous series. (4 marks)



## SECTION B: MECHANICAL SCIENCE

Answer *ONE* question from this section.

3. (a) Define the following terms and state their S.I units:

- (i) momentum;
- (ii) kinetic energy.

(4 marks)

(b) A truck of mass of 8 tonnes travelling at 20 m/s collides with a stationary van of mass 4 tonnes. Determine the loss of kinetic energy if the:

- (i) two vehicles move together after impact;
- (ii) truck comes to rest on impact.

(9 marks)

(c) (i) State the principle of conservation of energy.  
(ii) **Figure 1** shows a system of coplanar forces.

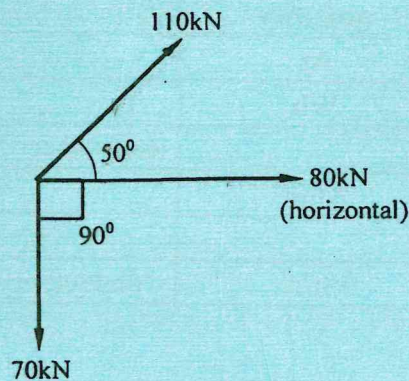

Fig. 1

By constructing a polygon of the forces, determine the magnitude and direction of the resultant force. (7 marks)

4. (a) (i) Explain the function of an engine governor.  
(ii) List **three** types of engine governors.

(5 marks)

(b) (i) State the principles of Archimedes.  
(ii) Explain the functions of the following components of a hydraulic coupling:

- (I) shell;
- (II) impeller;
- (III) turbine.

(8 marks)

2601/102  
2602/102  
2603/102

June/July 2023



- (c) With the aid of a labelled Temperature-Entropy (T - S) diagram, outline the processes of an ideal Carnot cycle for steam. (4 marks)
- (d) A body of mass 0.4 kg is attached to a shaft. The distance from the shaft axis to the centre of gravity of the body is 50 mm. Determine the centrifugal force on the body when the shaft rotates at 1000 rev/min. (3 marks)

### SECTION C: ELECTRICAL ENGINEERING PRINCIPLES

Answer any **THREE** questions from this section.

5. (a) Table 1 shows the electrical analogy of magnetic quantities.

Table 1

| Magnetic quantity           | Unity of magnetic quantity | Electrical analogy |
|-----------------------------|----------------------------|--------------------|
| Magnetomotive force (m.m.f) | At                         |                    |
| Magnetic flux               | Wb                         |                    |
|                             |                            | Resistance         |
| Magnetising force (H)       | At/m                       |                    |
| Flux density (B)            |                            |                    |
|                             | Wb/At                      | Conductivity       |

Copy and complete the table. (7 marks)

- (b) With the aid of a diagram, explain 'magnetic fringing' as applied to magnetic circuits. (4 marks)
- (c) Describe the operation of the permanent magnet moving coil indicating instrument. (4 marks)
- (d) With the aid of a circuit diagram, explain how a permanent magnet moving coil instrument can be converted to a multi-range ammeter. (5 marks)
6. (a) Explain each of the following terms as applied to electrical materials:
- resistivity;
  - temperature coefficient of resistance.

(4 marks)



- (b) The resistance of a coil of nickel wire at  $20\text{ }^{\circ}\text{C}$  is  $100\ \Omega$ . The temperature of the wire is increased and the resistance rises to  $130\ \Omega$ . If the temperature of nickel is  $0.006/^{\circ}\text{C}$  at  $20\text{ }^{\circ}\text{C}$ , determine the temperature of the wire when its resistance is  $130\ \Omega$ . (6 marks)
- (c) Explain **three** safety precautions to be taken when charging secondary cells. (6 marks)
- (d) Ten  $1.5\text{ V}$  cells, each having an internal resistance of  $0.1\ \Omega$  are connected in series to a load of  $14\ \Omega$ . Determine the:
- current flowing in the circuit;
  - potential difference at the battery terminals.
- (4 marks)
7. (a) State **three**:
- methods of varying the capacitance of a parallel plate capacitor;
  - applications of transformers.
- (6 marks)
- (b) With the aid of a labelled circuit diagram, describe the transformer short-circuit test. (8 marks)
- (c) Two capacitors are connected in series to a  $110\text{ d.c}$  supply. If the capacitors are of capacitance  $10\ \mu\text{F}$  and  $100\ \mu\text{F}$ , determine the:
- total circuit capacitance;
  - charge in the circuit;
  - energy stored by the  $100\ \mu\text{F}$  capacitor.
- (6 marks)
8. (a) Define 'electromotive force' as used in electric circuits and state its SI unit. (2 marks)
- (b) A capacitance of reactance  $30\ \Omega$  is connected in series with a non-inductive resistor of  $40\ \Omega$ . When the circuit is connected to an a.c supply, a current of  $4.6\text{ A}$  flows, if the supply frequency is  $50\text{ Hz}$ , determine the:
- supply voltage;
  - circuit power factor;
  - capacitance of the capacitor.
- (8 marks)



(c) Figure 2 shows a d.c electrical circuit.

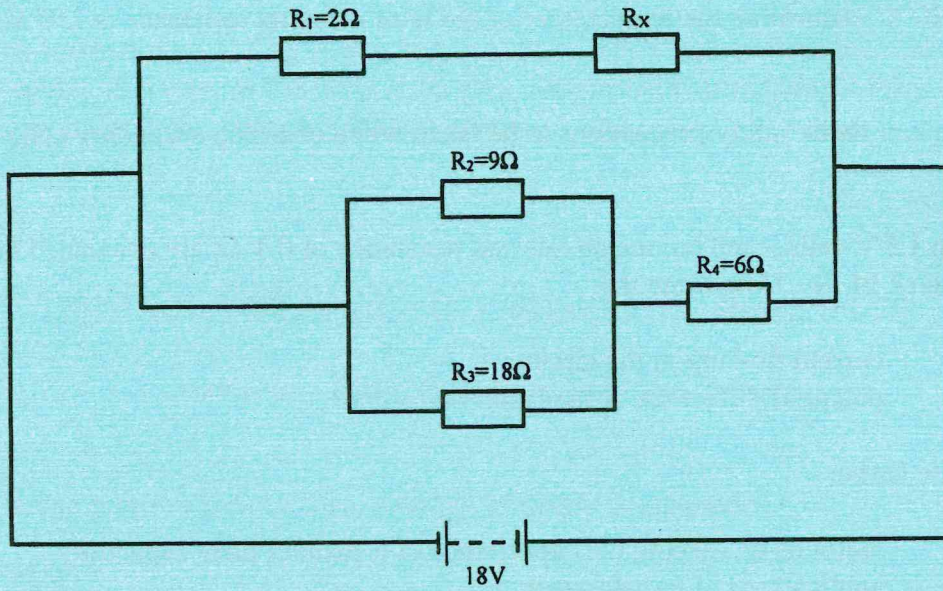

Fig. 2

If the supply current is 4.5 A, determine the:

- (i) total resistance of the circuit;
- (ii) value of resistor  $R_x$ ;
- (iii) power dissipated by the  $6\Omega$  resistor.

(10 marks)

THIS IS THE LAST PRINTED PAGE