

2601/201

2602/201

2603/201

**CONTROL SYSTEMS AND PROGRAMMABLE
LOGIC CONTROLLERS**

June/July 2022

Time: 3 hours



THE KENYA NATIONAL EXAMINATIONS COUNCIL

**DIPLOMA IN ELECTRICAL AND ELECTRONIC ENGINEERING
(POWER OPTION)
(TELECOMMUNICATION OPTION)
(INSTRUMENTATION OPTION)**

MODULE II

CONTROL SYSTEMS AND PROGRAMMABLE LOGIC CONTROLLERS

3 hours

INSTRUCTIONS TO CANDIDATES

You should have the following for this examination:

Answer booklet;

Drawing instruments;

Non-programmable scientific calculator;

Log linear paper

Polar curve.

*This paper consists of **EIGHT** questions in **TWO** sections; **A** and **B**.*

*Answer any **THREE** questions from section **A** and any **TWO** questions from section **B** in the answer booklet provided.*

Maximum marks for each part of a question are as indicated.

Candidates should answer the questions in English.

This paper consists of 11 printed pages and 2 inserts

Candidates should check the question paper to ascertain that all the pages are printed as indicated and that no questions are missing.

SECTION A: CONTROL SYSTEMS

Answer any **THREE** questions from this section.

1. (a) **Figure 1** shows a workman maintaining liquid level in a container at a specific level observed through a gauge glass. Identify each of the following parameters:

- (i) controlled variable;
- (ii) reference value;
- (iii) comparison element (comparator);
- (iv) error signal;
- (v) correction element.

(5 marks)

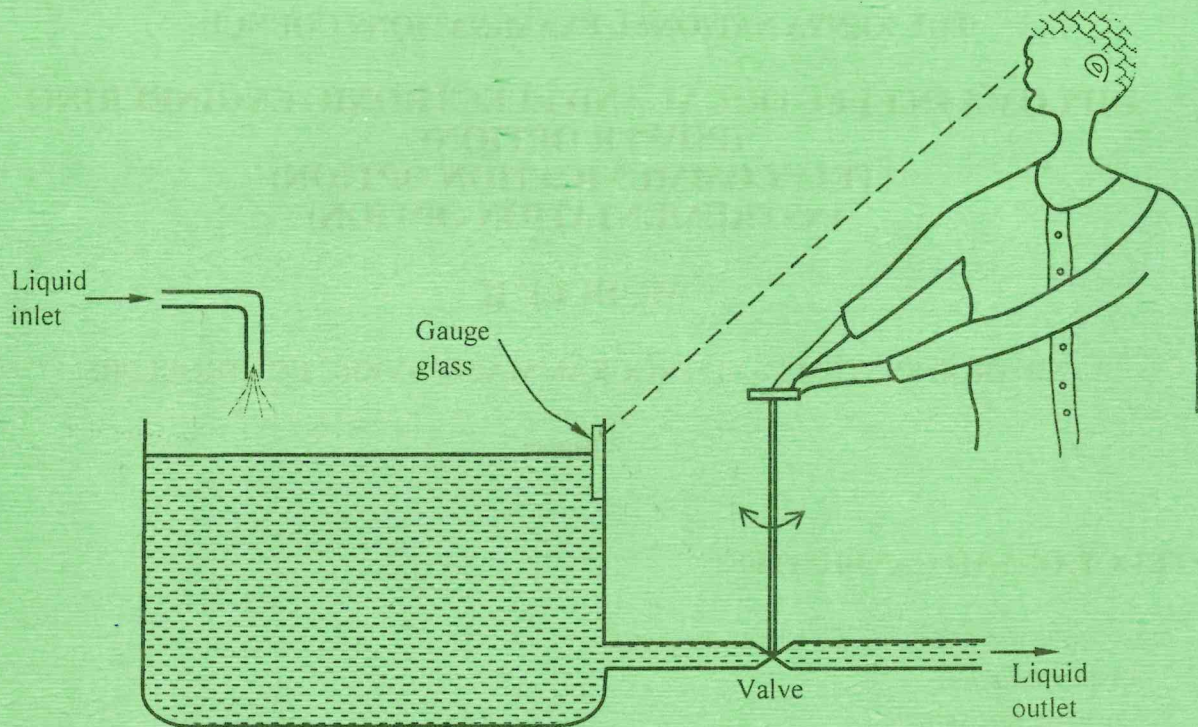

Fig. 1

- (b) **Figure 2** shows a diagram of phase lead electrical network. Show that its transfer function is given by:

$$\frac{V_{o(s)}}{V_{i(s)}} = \frac{a(1 + s\tau)}{1 + sa\tau}$$

given that $a = \frac{R_2}{R_1 + R_2}$ and $\tau = CR_1$

(11 marks)

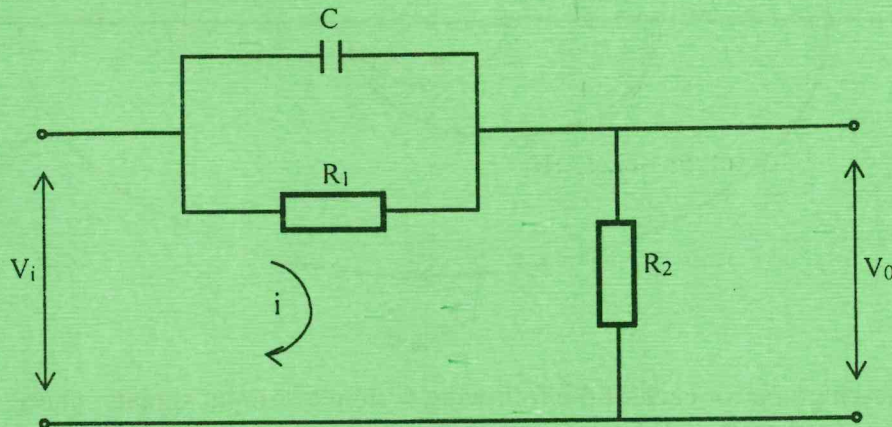

Fig. 2

- (c) State **two** advantages and **two** disadvantages of closed loop over open loop control systems. (4 marks)

2. (a) Derive a system model differential equation for a thermal system in which a thermometer at temperature T has just been inserted into a liquid at temperature T_L . Assume that the thermal resistance to heat flow is R , thermal capacitance of thermometer is C and the net rate of heat flow from liquid to thermometer is q .

(5 marks)

- (b) **Figure 3** shows a block diagram of a control system. Derive its transfer function using block diagram reduction technique. (9 marks)

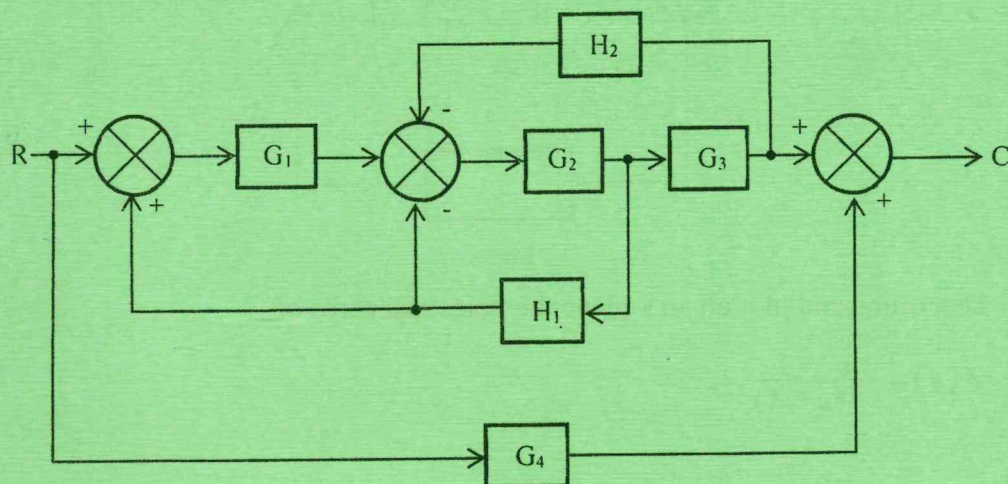

Fig. 3

- (c) **Figure 4** shows a signal flow graph of a control system. Obtain the closed loop transfer function. (6 marks)

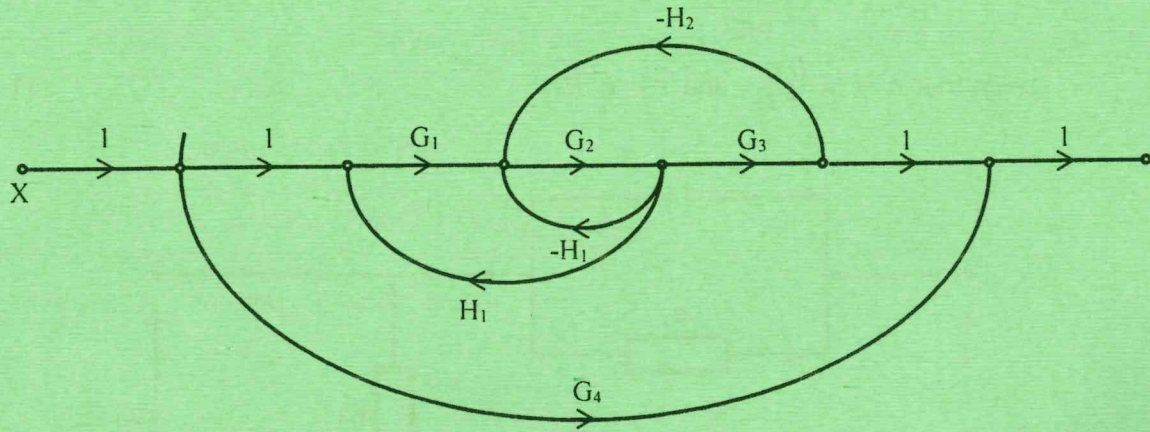

Fig. 4

3. (a) Sketch graph for each of the following system test input signals, stating the limitation associated with each:
- (i) ramp or constant velocity;
 - (ii) step. (4 marks)
- (b) **Figure 5** shows a block diagram of a control system. Determine the:
- (i) closed loop transfer function;
 - (ii) natural frequency;
 - (iii) damped natural frequency;
 - (iv) rise time. (10 marks)

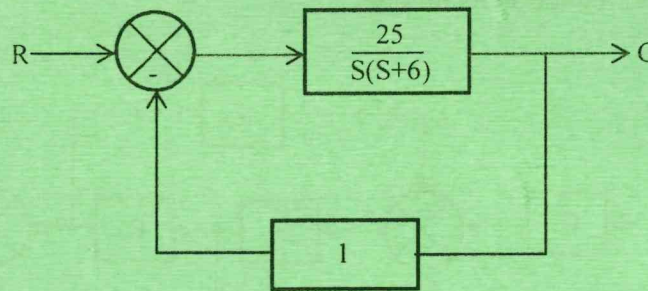

Fig. 5

- (c) Determine and plot on an s-plane the poles and zeros of:

$$F(s) = \frac{s^2 - 4}{s^3(s + 3)}$$

(6 marks)

4. (a) (i) State **two** merits of using Nyquist method when analysing system stability.
- (ii) Table 1 shows the open-loop frequency response of a control system. Construct its Nyquist diagram and hence determine:
- I. phase margin;
 - II. gain margin;
 - III. whether the system is stable, stating reasons for your answer.

(11 marks)

Table 1

ω (rad/s)	1.0	2.0	2.5	3.0	3.5	4.0	5.0	7.0	10
G	44	17	12	8.9	6.7	5.2	3.3	1.6	0.69
ϕ (degree)	-123	-146	-155	-163	-169	-175	-185	-199	-214

- (b) A control system has an amplitude scaled differential equation given as:

$$-\frac{d}{dt}\left(\frac{x}{5}\right) = [0.85]10\left(\frac{x}{5}\right) + [0.4]10(1)$$

Using the relation $\tau = \beta t$ time scaling method and given that time scale factor, $\beta = 10$:

- (i) derive the time scaled equation;
- (ii) obtain the amplitude and time scaled analog computer flow diagram;
- (iii) state with a reason, whether the problem is slowed down or speeded up.

(9 marks)

5. (a) (i) State **two** limitations of Routh's stability criterion.
- (ii) A negative unity feedback control system has a transfer function given by:

$$G(s)H(s) = \frac{k}{s^3 + 4s^2 + 11s}$$

Determine the minimum positive value of k at which the system becomes unstable.

(10 marks)

- (b) A unity feedback control system is described by:

$$G(s) = \frac{k}{s(1+s)(1+0.1s)}$$

The phase plot values are shown in Table 2.

Table 2

ω (rad/sec)	0	0.1	0.5	1	3	5	10
ϕ (degree)	-90°	-96.3°	-119.4°	-140.7°	-178.3°	-195°	-219°

- (i) Draw the Bode plot for the system when $k = 1$.
- (ii) Determine from the Bode plot the value of k so as to have:
- I. gain margin = 10 db;
 - II. phase margin = 50°
- (10 marks)

SECTION B: PROGRAMMABLE LOGIC CONTROLLERS

Answer any *TWO* questions from this section.

6. (a) (i) State two reasons why relays may be used instead of PLCs.
- (ii) Explain the function of each of the following in a PLC:
- I. CPU;
 - II. indicator lights.
- (6 marks)
- (b) **Figure 6** a circuit diagram of a PLC output interface:

- (i) identify the type of interface;
- (ii) explain the principle of operation and function of each of the components in the circuit.
- (7 marks)

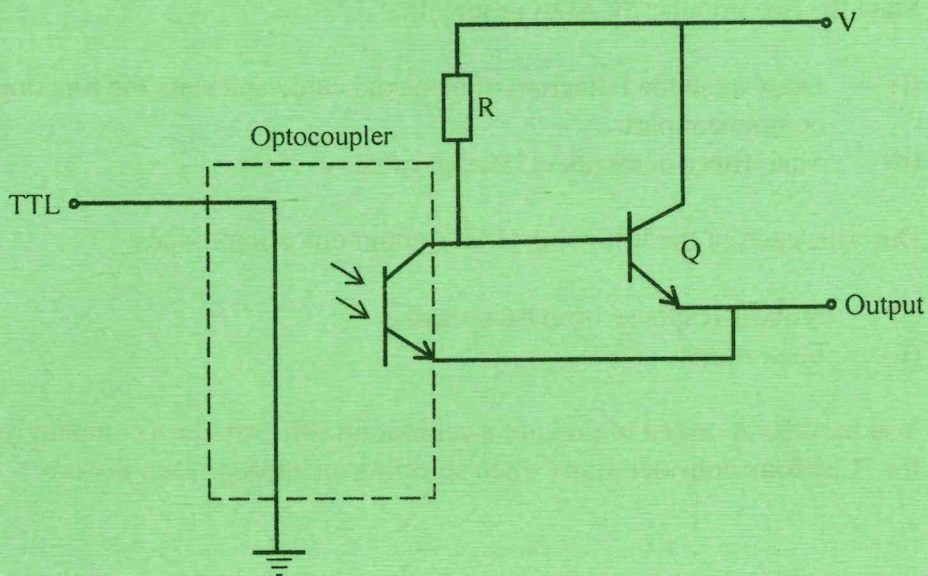
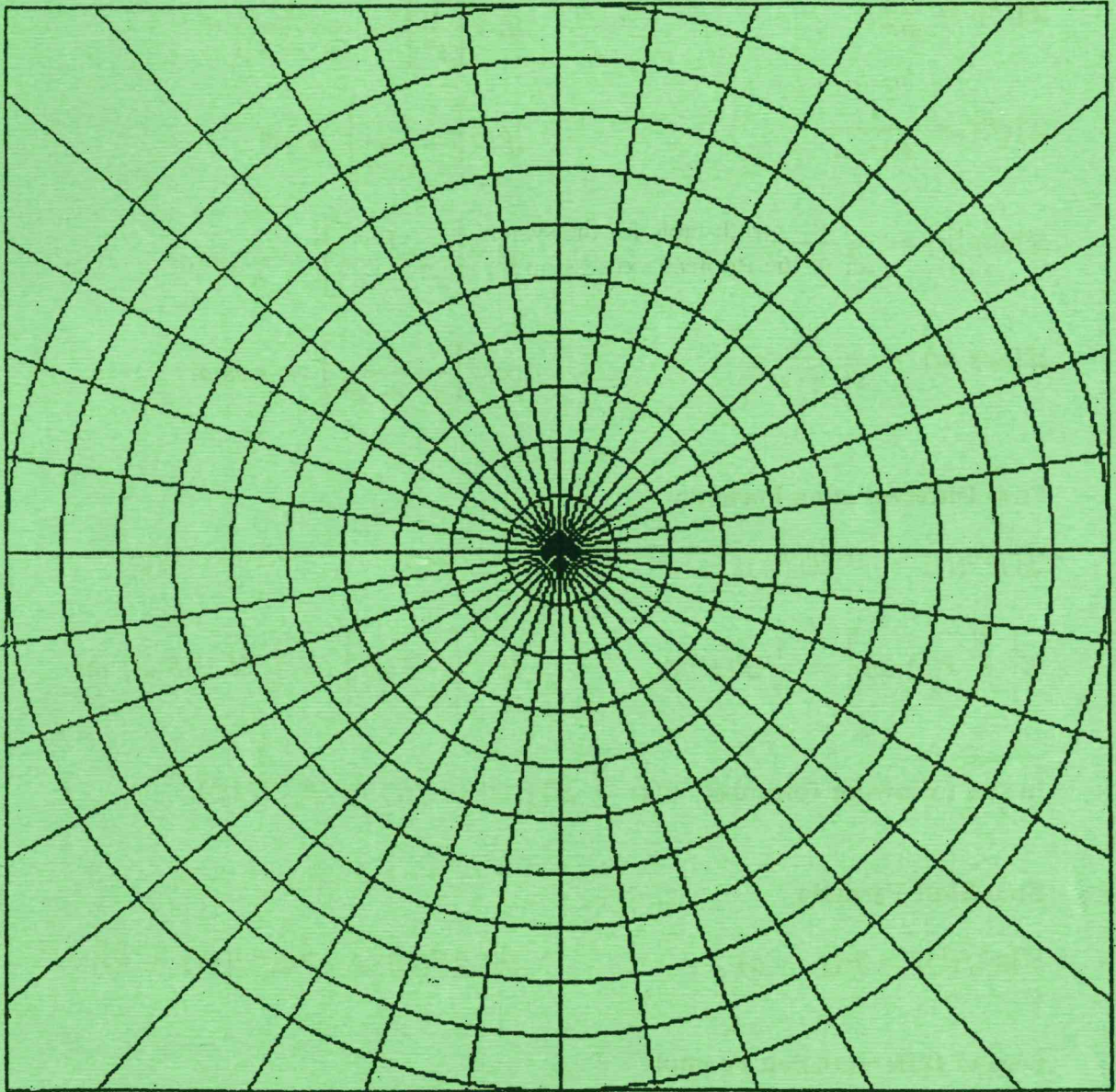

Fig. 6

- (c) A PLC program memory chip has data lines labelled as $D_0 - D_7$ and address line as $A_0 - A_9$. Determine for this chip the:
- (i) word size;
 - (ii) maximum number of addressable memory locations;
 - (iii) memory capacity in kilobytes.
- (7 marks)

7. (a) A PLC controlled burglar alarm system has the following components and conditions:
- A siren (A) that sounds when an intruder is detected.
 - A motion sensor (M) that turns ON when it detects a motion.
 - A window sensor (W) configured as normally - closed contact that opens when window is broken.
 - An alarm activate/ deactivate main switch (S) that is activated when the home owner want to engage the system.
- (i) Draw the truth-table for the system;
- (ii) Derive the Boolean expression for siren ON;
- (iii) Draw the ladder diagram for the expression obtained in (ii). (11 marks)
- (b) Draw a labelled layout diagram of a second generation SCADA architecture and describe the types of networks used in the system. (7 marks)
- (c) State the two popular SCADA protocols. (2 marks)
8. (a) (i) Draw a labelled diagram of a coaxial cable and state the function of its component parts.
- (ii) State **three** demerits of coaxial cable. (10 marks)
- (b) Describe each of the following HART communication modes:
- (i) request-response or master-slave;
- (ii) burst mode. (6 marks)
- (c) You have been tasked to procure a calibration software for a company you are working for. List **four** considerations when selecting an appropriate software. (4 marks)



POLAR CURVE

2601/201
2602/201
2603/201
June/July 2022

Turn over

TABLE OF LAPLACE TRANSFORM FORMULAS

$$\mathcal{L}[t^n] = \frac{n!}{s^{n+1}}$$

$$\mathcal{L}^{-1}\left[\frac{1}{s^n}\right] = \frac{1}{(n-1)!} t^{n-1}$$

$$\mathcal{L}[e^{at}] = \frac{1}{s-a}$$

$$\mathcal{L}^{-1}\left[\frac{1}{s-a}\right] = e^{at}$$

$$\mathcal{L}[\sin at] = \frac{a}{s^2 + a^2}$$

$$\mathcal{L}^{-1}\left[\frac{1}{s^2 + a^2}\right] = \frac{1}{a} \sin at$$

$$\mathcal{L}[\cos at] = \frac{s}{s^2 + a^2}$$

$$\mathcal{L}^{-1}\left[\frac{s}{s^2 + a^2}\right] = \cos at$$

First Differentiation Formula

$$\mathcal{L}[f^{(n)}(t)] = s^n \mathcal{L}[f(t)] - s^{n-1}f(0) - s^{n-2}f'(0) - \dots - f^{(n-1)}(0)$$

$$\mathcal{L}\left[\int_0^t f(u) du\right] = \frac{1}{s} \mathcal{L}[f(t)]$$

$$\mathcal{L}^{-1}\left[\frac{1}{s} F(s)\right] = \int_0^t \mathcal{L}^{-1}[F(s)] du$$

In the following formulas, $F(s) = \mathcal{L}[f(t)]$ so $f(t) = \mathcal{L}^{-1}[F(s)]$.

First Shift Formula

$$\mathcal{L}[e^{at}f(t)] = F(s-a)$$

$$\mathcal{L}^{-1}[F(s)] = e^{at} \mathcal{L}^{-1}[F(s+a)]$$

Second Differentiation Formula

$$\mathcal{L}[t^n f(t)] = (-1)^n \frac{d^n}{ds^n} \mathcal{L}[f(t)]$$

$$\mathcal{L}^{-1}\left[\frac{d^n F(s)}{ds^n}\right] = (-1)^n t^n f(t)$$

Second Shift Formula

$$\mathcal{L}[u_a(t)g(t)] = e^{-as} \mathcal{L}[g(t+a)]$$

$$\mathcal{L}^{-1}[e^{-as}F(s)] = u_a(t)f(t-a)$$

Log 6 Cycles x 2, 10 and 20 min.

Chartwell Graph Data Ref. 8562

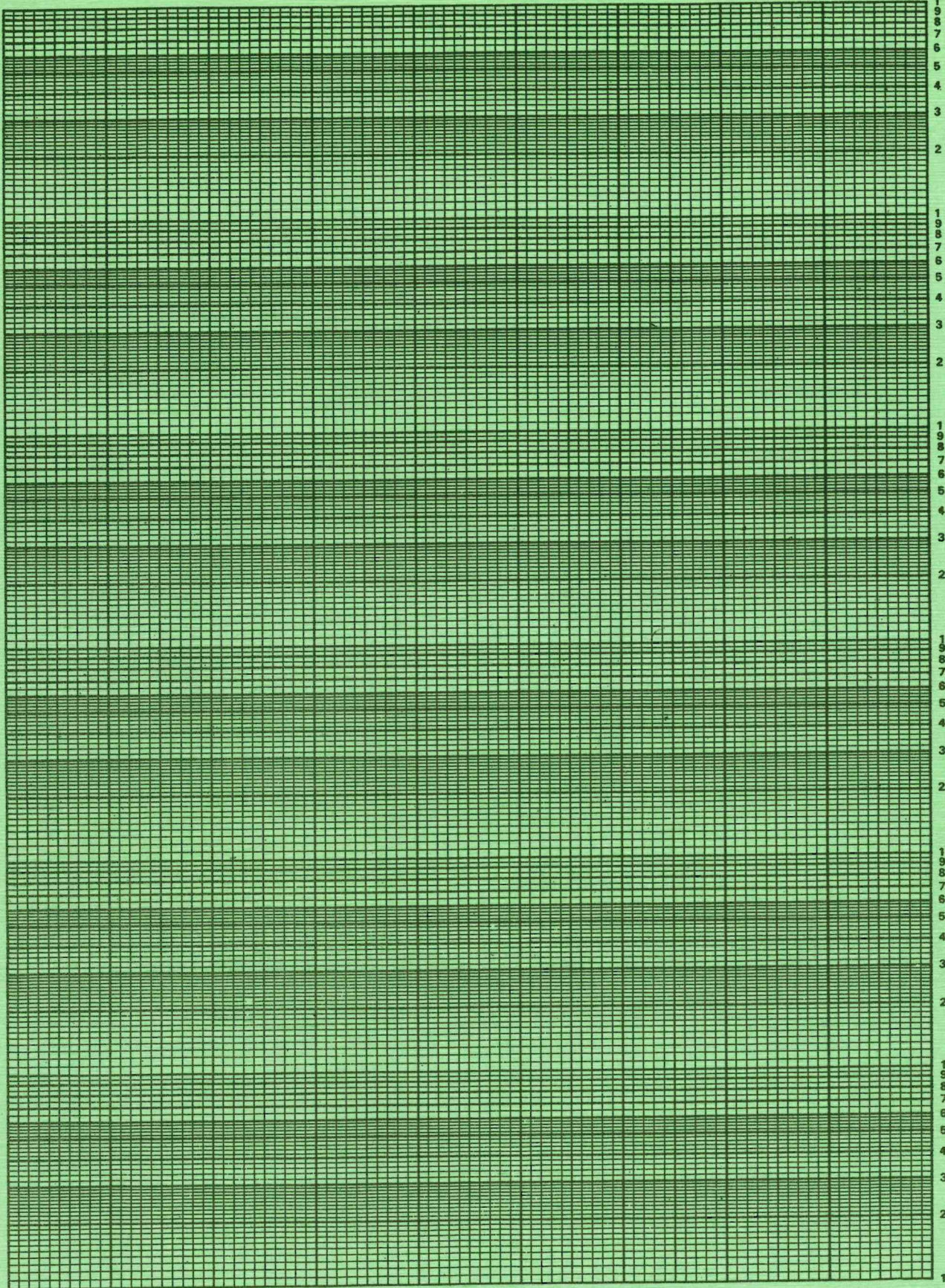

THIS IS THE LAST PRINTED PAGE.

2601/201
2602/201
2603/201
June/July 2022

Name Index No.

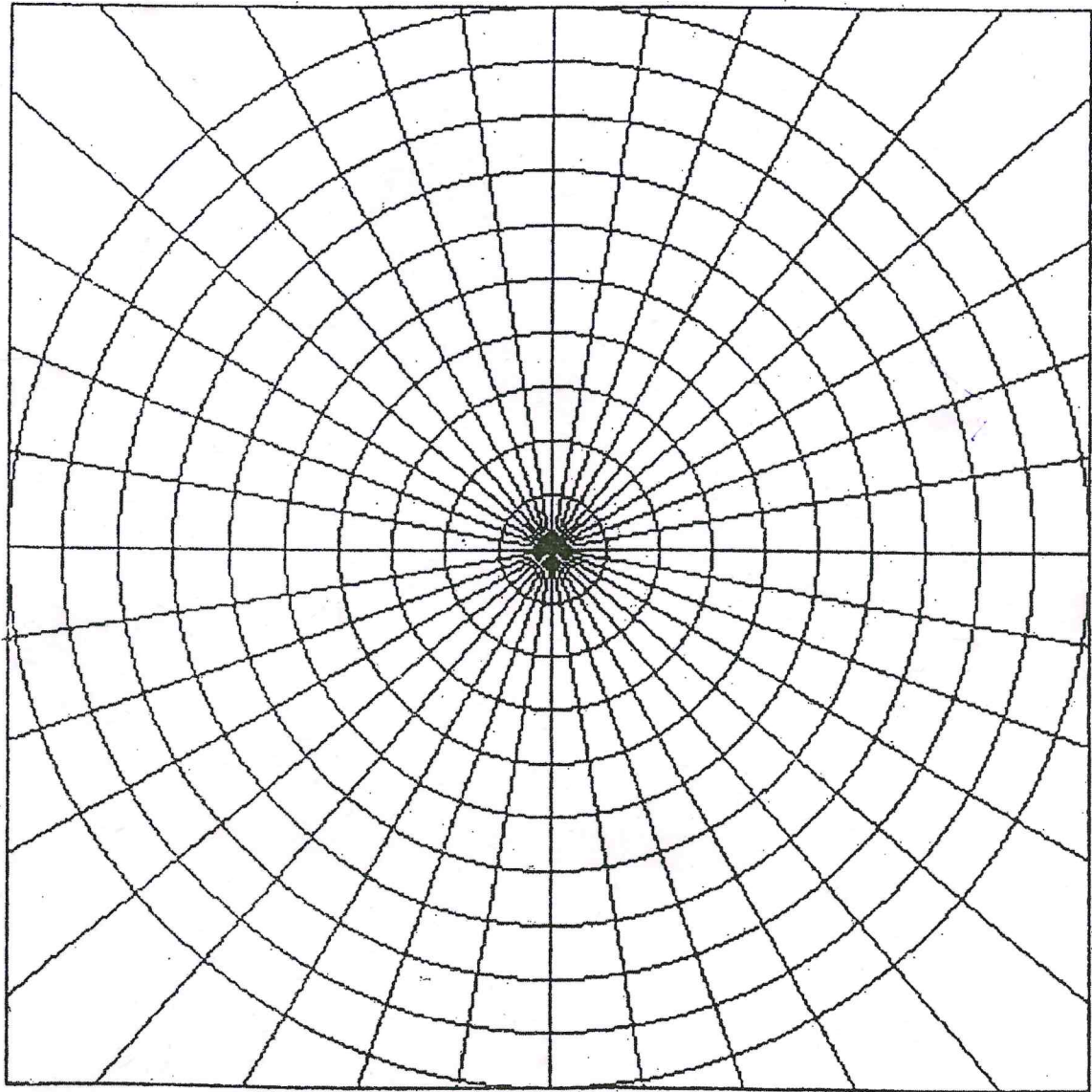

POLAR CURVE