

2507/201
AIRCRAFT INSTRUMENTS AND
MEASUREMENT SYSTEMS
June/July 2019
Time: 3 hours



THE KENYA NATIONAL EXAMINATIONS COUNCIL
DIPLOMA IN AERONAUTICAL ENGINEERING
(AVIONICS OPTION)

MODULE II

AIRCRAFT INSTRUMENTS AND MEASUREMENT SYSTEMS

3 hours

INSTRUCTIONS TO CANDIDATES

You should have the following for this examination:

Answer booklet;

Drawing instruments;

Mathematical tables/Non-programmable scientific calculator.

This paper consists of EIGHT questions. Answer FIVE questions.

All questions carry equal marks.

Maximum marks for each question are as indicated.

Candidates should answer the questions in English.

This paper consists of 3 printed pages.

Candidates should check the question paper to ascertain that all the pages are printed as indicated and that no questions are missing.

1. (a) Explain each of the following when performing calculations using the various systems of units:
- (i) ESU;
 - (ii) MKS. (4 marks)
- (b) Explain each of the following as applied to a working standard:
- (i) reference standard;
 - (ii) check standard. (2 marks)
- (c) Describe each of the base units that define the international system of measurement (S.I). (14 marks)
2. (a) Explain the difference in operation between circuits (A) and (B) in measurement of power in DC circuits. (6 marks)

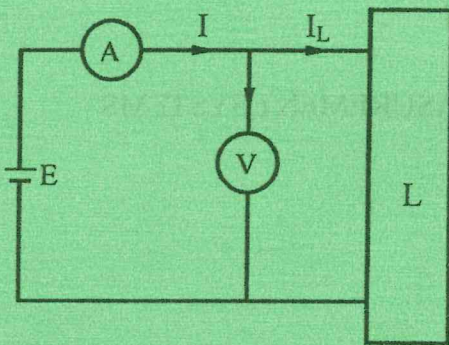

Fig. (A)

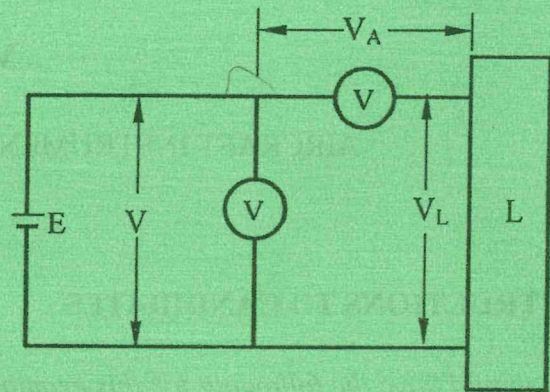

Fig. (B)

- (b) With the aid of a labelled diagrams, discuss the thermocouple method of power measurement. (14 marks)
3. (a) Highlight the procedure of carrying out serviceability checks on a simple sensitive altimeter under the following headings:
- (i) visual inspection; (1 mark)
 - (ii) zeroing; (1 mark)
 - (iii) case leak check; (3 marks)
 - (iv) accuracy check; (9 marks)
 - (v) lag check. (1 mark)
- (b) With the aid of a labelled sketch, show the construction of an airspeed indicator. (5 marks)

4. (a) Describe each of the following types of gyroscopes:
- (i) free gyro;
 - (ii) tied gyro;
 - (iii) rate gyro;
 - (iv) earth tied gyro. (8 marks)
- (b) With the aid of a labelled sketch, show the parts of a ring laser gyro. (9 marks)
- (c) Explain the factors that determine the rate of precession. (3 marks)
5. (a) (i) With the aid of a labelled sketch, explain the principle of operation of a standard Newtonian reflecting telescopes.
- (ii) Outline **three** advantages of 5(a)(i) over other types. (12 marks)
- (b) Explain **four** errors that can be adjusted by the navigator in a sextant. (8 marks)
6. (a) With the aid of a labelled sketch, show the correct layout of the basic six flying instruments. (6 marks)
- (b) Describe the artificial horizon. (6 marks)
- (c) Explain the reasons for fitting aircraft with a radio altimeter. (4 marks)
- (d) Outline **four** serviceability checks that should be carried on a direct reading compass. (4 marks)
7. (a) Discuss the function of central maintenance computer function (CMCF) in central management system. (7 marks)
- (b) With the aid of a labelled block diagram of a typical layout of central maintenance system interface, show how the information is indicated to the flight and maintenance crew. (13 marks)
8. (a) With the aid of a labelled bathtub curve, describe the various types of equipment failure. (14 marks)
- (b) With reference to the aircraft flight data recorder, discuss each of the following:
- (i) purpose;
 - (ii) modern design requirements. (6 marks)

THIS IS THE LAST PRINTED PAGE.