

Name _____

Index No. _____

2601/102

Candidate's Signature _____

2602/102

2603/102

Date _____

PHYSICAL SCIENCE, MECHANICAL
SCIENCE AND ELECTRICAL
ENGINEERING PRINCIPLES

Oct/Nov 2014

Time: 3 hours



THE KENYA NATIONAL EXAMINATIONS COUNCIL

DIPLOMA IN ELECTRICAL AND ELECTRONICS ENGINEERING
(POWER OPTION)
(TELECOMMUNICATION OPTION)
(INSTRUMENTATION OPTION)
MODULE I

PHYSICAL SCIENCE, MECHANICAL SCIENCE
AND ELECTRICAL ENGINEERING PRINCIPLES

3 hours

INSTRUCTIONS TO CANDIDATES

Write your name and index number in the spaces provided above.

Sign and write the date of the examination in the spaces provided above.

You should have mathematical tables/scientific calculator for this examination.

Take $U^0 = 4\pi \times 10^{-7}$

This paper consists of **EIGHT** questions in **THREE** sections; **A**, **B** and **C**.

Answer **ONE** questions from Section **A** and **ONE** question from Section **B** and **THREE** questions from Section **C** in the spaces provided in this question paper.

All questions carry equal marks.

Maximum marks for each part of a question are as shown.

Do **NOT** remove any pages from this booklet.

Candidates should answer the questions in English.

For Examiner's Use Only

Section	Maximum Score	Candidate's Score
A		
B		
C		
Total Score	100	

This paper consists of 20 printed pages.

Candidates should check the question paper to ascertain that all the pages are printed as indicated and that no questions are missing.

© 2014 The Kenya National Examinations Council

Turn over

SECTION A

Answer *ONE* questions from this Section.

1. (a) Define the following terms as applied to simple harmonic motion:
- (i) amplitude;
 - (ii) frequency;
 - (iii) periodic time. (3 marks)
- (b) A body moves with a simple harmonic motion. When this point is 0.75 m from the mid point, its velocity is 11 m/s and when the point is 2 m, from the centre of its path, its velocity is 3 m/s. Determine:
- (i) the angular velocity of the body;
 - (ii) the periodic time. (9 marks)
- (c) (i) state the following laws:
- I. Boyle's law;
 - II. Dalton's law of partial pressure.
- (ii) A body has a volume of 0.08 m^3 and contains a mixture of helium and hydrogen at a pressure of 450 kPa and temperature of 17°C . If the mass of helium present is 0.4 kg. Determine:
- I. The partial pressure for each gas.
 - II. The mass of hydrogen present.
- Assume gas constant for Helium to be 2080 J/kg and for Hydrogen to be 4160 J/kg. (8 marks)
2. (a) (i) Define the following terms as applied to heat:
- I. specific latent heat of vaporisation;
 - II. specific latent heat of fusion.

- (ii) Determine the amount of heat energy required to change 400 g of ice initially at $-20\text{ }^{\circ}\text{C}$ into steam at $120\text{ }^{\circ}\text{C}$.

Assume the following:

Latent heat of fusion of ice	= 335 kJ/kg
Latent heat of vaporisation of water	= 2260 kJ/kg
Specific heat capacity of ice	= 2.14 kJ/kgk
Specific heat capacity of water	= 4.2 kJ/kgk
Specific heat capacity of steam	= 2.01 kJ/kgk

(10 marks)

- (b) Differentiate the following:

- (i) longitudinal wave and Transverse wave;
(ii) diffraction and refraction of sound.

(4 marks)

- (c) (i) State the principle of superposition as applied to waves.

- (ii) With aid of a diagram, explain damped vibration.

(6 marks)

SECTION B

Answer ONE question from this Section.

3. (a) With aid of a stress - strain graph, explain the behaviour of a mild steel subjected to tensile test until destruction. (7 marks)
- (b) (i) State the law of conservation of energy;
(ii) Derive the expression for kinetic energy. (6 marks)
- (c) (i) State Newton's second law of motion;
(ii) A bullet of mass 20 g, travelling horizontally at 100 m/s embeds itself in the centre of a block of wood of mass 1 kg which is suspended by a light string 1 m long. Determine the maximum inclination of the string to the vertical. Assume $g = 9.81\text{ m/s}^2$.

(7 marks)

4. (a) Define the following terms as applied to angular motion:
- (i) angular velocity;
 - (ii) angular acceleration. (2 marks)
- (b) An object is suspended by a thread 250 mm long and both object and thread move in a horizontal circle with a constant angular velocity of 2.0 rad/sec. If the tension in the thread is 12.5 N, determine the mass of the object. (6 marks)
- (c) (i) State **two** instruments used for measuring pressure in fluids.
- (ii) State **two** advantages and two disadvantages of venturi meter as used in measuring flow rate.
- (iii) With aid of a diagram, explain the principle of operation of a centrifugal governor as used in turbine speed governing system. (12 marks)

SECTION C

*Answer any **THREE** question from this Section.*

5. (a) Distinguish between primary and secondary cells giving one example in each case. (4 marks)
- (b) (i) With the aid of a labelled diagram, explain the operation of a permanent magnet moving coil instrument.
- (ii) A moving coil instrument having a resistance of 10Ω gives a full scale deflection when a current of 8 mA flows. Determine the value of the multiplier to be connected in series with the instrument so that it can be used as a voltmeter to measure up to 100 V. (7 marks)
- (c) Using Kirchoff's laws, determine the currents flowing in each of the resistors of the bridge network shown in figure 1. (9 marks)

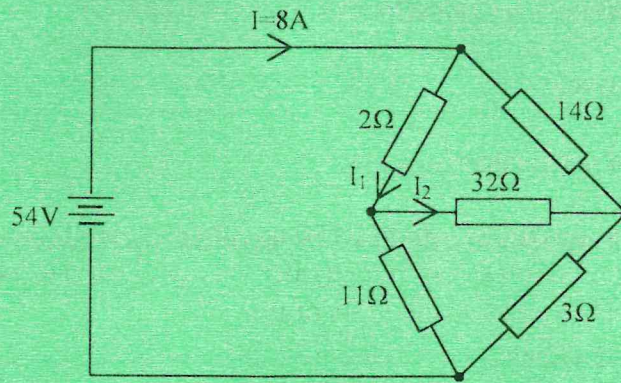

Fig. 1

6. (a) State Faraday's laws of electromagnetic induction. (2 marks)
- (b) Two coils have a mutual inductance of 0.2 H. If the current in one coil is changed from 10A to 4A in 10 ms, determine the:
- (i) average induced e.m.f in the second coil;
- (ii) change of flux in the second coil if it has 100 turns. (6 marks)
- (c) (i) Define the following terms as used in electrostatics:
- I. capacitance;
- II. electric field intensity.
- (ii) Two capacitors with capacitances of $6 \mu\text{F}$ and $4 \mu\text{F}$ are connected in series across a 100 V supply. If the supply is cut-off and the two capacitors are connected in parallel, determine the final charge of the $4 \mu\text{F}$ capacitor. (12 marks)
7. (a) An alternating voltage is given by the expression $V = 75 \sin (200 \pi t - 0.25)$ volts. Determine the :
- (i) peak-to-peak value;
- (ii) r.m.s value;
- (iii) periodic time. (6 marks)
- (b) A capacitor C is connected in series with a 40Ω resistor across a supply of frequency 50 Hz. If the total circuit impedance is 50Ω and the current flowing is 3 A, determine the:

2601/102
2602/102
2603/102

- (i) value of the capacitor C;
- (ii) phase angle;
- (iii) voltage across the capacitor. (8 marks)

(c) – With the aid of waveforms, describe the relationship between a.c. current and voltage in purely:

- (i) resistive circuit;
- (ii) capacitive circuit;
- (iii) inductive circuit. (6 marks)

8. (a) (i) Define the term ‘transformation ratio’ as used in transformers.

(ii) An ideal single-phase transformer connected to a 240 V mains, supplies a 12 V, 150 W lamp. Determine the current taken from the supply. (6 marks)

(b) Explain the following transformer losses:

- (i) copper losses;
- (ii) eddy current losses. (4 marks)

(c) (i) Draw a labelled equivalent circuit of a transformer on no-load.

(ii) With the aid of a labelled diagram, explain the no-load test of a transformer. (10 marks)